

13" Automatic Bandsaw



MODELS BS300HAS

Features:

- Precise cut off length setting
- Auto head-elevation and quick approach control
- Piece counter with auto shutoff
- Multiple stroke counter for long pieces, 9 strokes standard
- Power-driven blade cleaning brush and coolant cleaning flush hose
- Idle wheel motion detector
- Carbide and roller blade guides
- Shuttle vise back-jaw feed method (no need for front stop)
- Unique two-way vise jaw.
- Safety and thermal overload switches
- Guarded blades and wheel covers
- Low voltage controls
- Blade breakage sensor/motion detector provides automatic shutoff
- Two year limited warranty

Specifications

Model	BS300HAS
Drive Motor	5 Hp, 230/460v 3 ph (other voltages optional)
Hydraulic Motor	1 Hp
Hydraulic oil capacity	8 gal.
Bandwheel Dia.	16 1/2"
Blade Speeds	108-430 fpm Inf. variable speed
Blade	1 1/4" x .042" x 12'-6 1/2"
Coolant	Recirculating
Coolant Capacity	15 gal.
90° Cutting Capacity	
Round	12 3/4"
Rectangular	12 3/4" x 10"
*Bundle Cutting	10" x 6 1/2"
Height (head-up) (A)	75"
Base Width (B)	55"
Width (C)	74"
Height (head-down) (D)	51"
Bed Height (E)	23"
Base Depth (F)	29"
Base & Feed Table Depth (G)	64"
Depth (H)	77"
Net Weight	3100 lbs.
Shipping Weight	3600 lbs.

BS300HAS Cutting Capacities:

Capacity at 90°

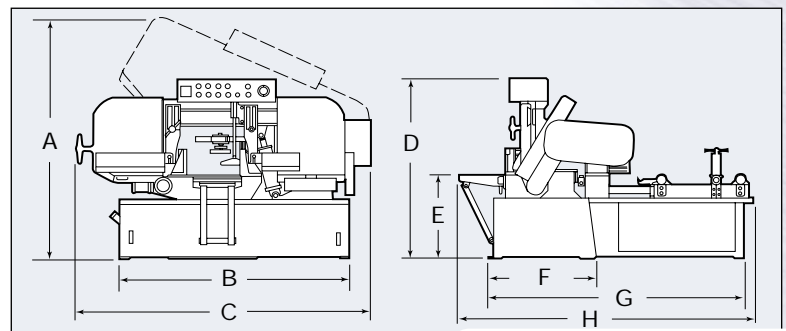
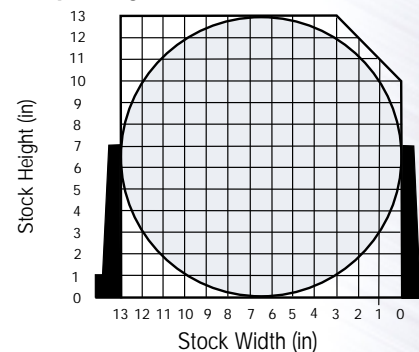

* When equipped with optional hydraulic bundle cutting attachment



Humston Machinery, Inc.

10813 DeAndrea Drive
Zionsville, IN 46077
(317) 873-3765
Fax: (317) 873-5690
www.humstonmachinery.com